

WGI Packager Needle Valves – Instrumentation Valve

Carbon Steel / Stainless Steel

Specifications

Sizes

1/4" Through 1"NPT

Maximum Operating Pressure

6000 psi

Body & Bonnet Material

A105 Carbon steel or 316 Stainless Steel

Stem Material

316 Stainless steel

Stem Packing

PTFE Teflon®

Stem

Non Rotating – 1/2" NPT and larger

Temperature Rating

-40° to 500°F (-40 to 250°C)



WN1432P

Dimensions & Part Numbers

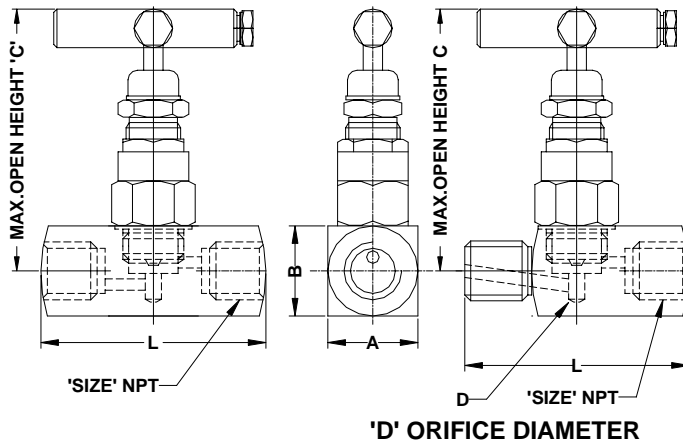

'D' ORIFICE DIAMETER

Part No.	Size	Pattern	Ends	Material	A	B	C	L	D
WN1412P	1/4"	G	FxF	316SS	22.0	22.0	74.0	54.0	03.2
WN1413P	3/8"	G	FxF	316SS					
WN1414P	1/2"	G	FxF	316SS	28.5	28.5	68.0	76.0	03.2
WN1416P	3/4"	G	FxF	316SS					
WN1418P	1"	G	FxF	316SS					
WN1432P	1/4"	G	MxF	316SS	22.0	22.0	74.0	54.0	03.2
WN1433P	3/8"	G	MxF	316SS					
WN1434P	1/2"	G	MxF	316SS	28.5	28.5	68.0	76.0	03.2
WN1436P	3/4"	G	MxF	316SS					
WN1437P	3/4"x 1/2"	G	MxF	316SS	30.0	30.0	70.0	76.0	4.0
WN1438P	1"	G	MxF	316SS					
WN1612P	1/4"	G	FxF	CS	22.0	22.0	74.0	54.0	03.2
WN1613P	3/8"	G	FxF	CS					
WN1614P	1/2"	G	FxF	CS	28.5	28.5	68.0	76.0	03.2
WN1616P	3/4"	G	FxF	CS					
WN1618P	1"	G	FxF	CS					
WN1632P	1/4"	G	MxF	CS	22.0	22.0	68.0	54.0	03.2
WN1633P	3/8"	G	MxF	CS					
WN1634P	1/2"	G	MxF	CS	28.5	28.5	84.0	76.0	03.2
WN1636P	3/4"	G	MxF	CS					
WN1637P	3/4"x 1/2"	G	MxF	CS	30.0	30.0	70.0	76.0	4.0
WN1638P	1"	G	MxF	CS					

Pressure / Temperature Chart

Standard 6000 PSI Hand Valves

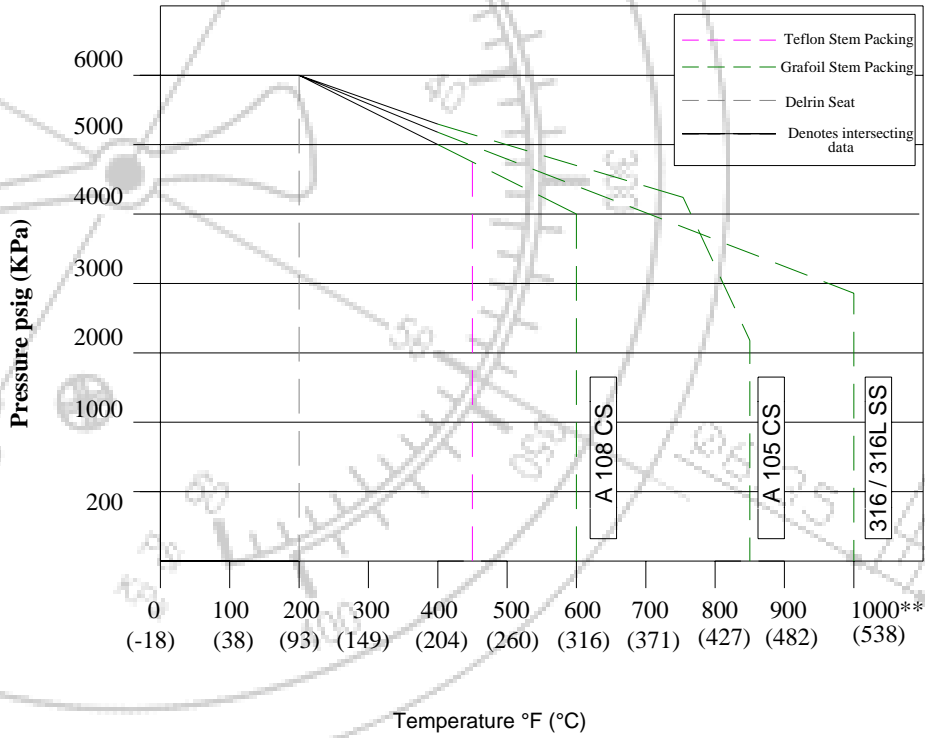

Temperature Ratings

Body Materials

	Maximum °C / °F
316 / 316L SS	1000 °C / 425 °F
A 105 CS	454 °C / 850 °F
A 108 CS	315 °C / 600 °F

Seat Materials

	Maximum °C / °F
316 / 316L SS	538 °C / 1000 °F
Delrin	93 °C / 200 °F

Stem Seal Materials

	Maximum °C / °F
Viton	204 °C / 400 °F
Teflon	232 °C / 450 °F
Grafoil	538 °C / 1000 °F