

3-way Reg. Port SS Ball Valve - Direct Mount* **FLOW+ B07/L/T**

* See page 14 for Actuation

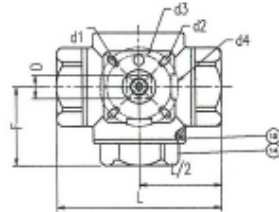

Size	dia (mm)	L	F	ISO 5211	D	H	D1	A	C	d1	d2	H1	W (kg)	Cv
1/2"	12.7	75.7	37.25	42	9	77.45	112	8.5	12	6	7.5	40.65	0.67	5.4
				50										
3/4"	16.0	86.6	44.7	F04	9	82	112	8.5	12	7.5	9.5	45.2	1.07	12
				F05										
1"	20.0	102.4	51.4	F05	11	93.7	136.5	11.4	15.8	7.5	9.5	56.5	1.68	15
				F07										
1-1/2"	32.0	125.8	62.7	F05	14	120.25	197.5	14	20.8	7.5	9.5	73.5	3.6	34
				F07										
2"	38.1	149	74.6	F05	14	129.85	197.5	13.7	20.8	9.5	11	87.35	5.8	47
				F07										

Pressure rating: 1000 psi (69 Bar) WOG for 1/4" to 2"
 High Cycle, Live Loaded, Triple Stem Seal comprising of:

- Carbon Filled PTFE Wedge Ring Thrust Washer
- Viton O-Ring
- 15% RTFE Chevron packing
- Live loaded Belleville Washers
- Packing Nut Mechanically Locked to Stem

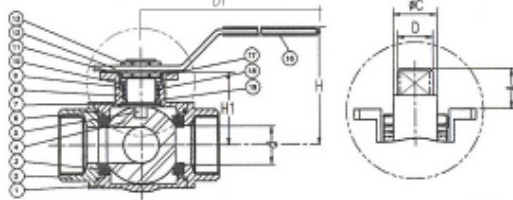

POSITION TYPE	1	2	3	4
L	1 1/2 2/3	1 1/2 2/3		
T	1 1/2 2/3	1 1/2 2/3	1 1/2 2/3	1 1/2 2/3

Features:

- Anti-static device, L-port, T-port
- Blow-out proof stem
- FNPT end connections
- Locking Handle
- Material: ASTM A351 GR.CF8M (316SS)

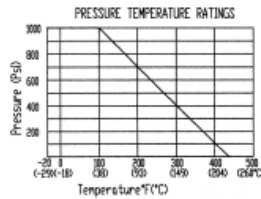

No	Parts	Material
01	Body	ASTM-A351GR.CF8M
02	End Cap	ASTM-A351GR.CF8M
03	Seat	15% RTFE
04	Ball	ASTM-A351GR.CF8M
05	Stem	S. S. 316
06	Gasket	15% RTFE
07	Thrust Washer	PTFE + 25% Carbon
08	Stem Packing	15% RTFE
09	Gland	S.S. 304
10	Belleville Washer	SUS 304-CSP
11	Stem Nut	S. S. 304
12	Handle	S. S. 304
13	Handle Nut	S. S. 304
14	End Cap	ASTM A351 GR.CF8M
15	Gasket	15% RTFE
16	Handle Sleeve	Vinyl Grip
17	Locking Washer	SUS 304-CSP
18	Thrust Washer	PTFE+25% G/F
19	O-Ring	Viton

2-PC Full Port Carbon Steel Ball Valve **FLOW+ B11**



Size	dia (mm)	L	H	W	S	S1	X	N	P	C1	C2	BL	Cv Factor	Wt (kg)
1/4"	11.6	60.5	53	105	16.5	10.2	5	12.5	28.5	26	42.5	5/16"	7	0.3
3/8"	12.7	60.5	53	105	16.5	10.2	5	12.5	28.5	26	42.5	5/16"	7	0.3
1/2"	15	62.5	53	105	16.5	10.2	5	12.5	28.5	26	42.5	5/16"	15	0.35
3/4"	20	77	60	125	20	13.5	6.5	21	34.8	32.2	52.3	3/8"	45	0.58
1"	25.4	90	74	160	23.5	16	8	22.5	34.8	39.2	63.1	7/16"	65	1.04
1-1/4"	32	100	80	160	23.5	16	8	23.5	38.1	45.3	68.7	7/16"	125	1.54
1-1/2"	38	118	92	190	25.5	17	9	23.5	38.1	53.4	78.9	1/2"	175	2.3
2"	50.8	138	101	190	25.5	17	9	34	38.1	62.6	88.2	1/2"	380	3.8
2-1/2"	65	167	130	245	41	29.5	12	35	56	77	118.8	3/4"	500	6.8
3"	80	193	142	245	41	29.5	12	35	56	88.8	130.3	3/4"	900	11.6
4"	100	260	174	325	48	36.5	16	50	63	109.6	158.8	1"	1250	23

Pressure rating:

- 2000 psi (137.8 Bar) WOG for 1/4" to 1-1/4"
- 1500 psi (103.4 Bar) WOG for 1-1/2" to 3"

Features:

- Carbon Steel Body and Cap
- Material: ASTMA216-WCB
- Blow-out proof stem / Full Port
- FNPT threaded on both ends
- Locking Handle

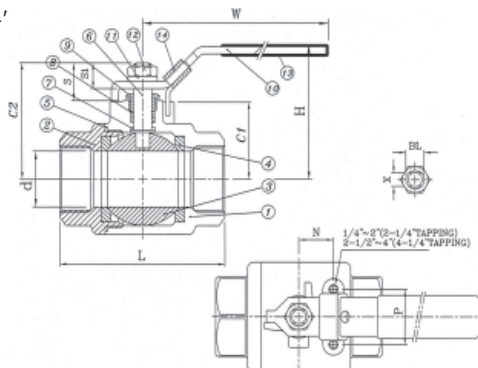

No	Parts for B11	Qty	Material
01	Body	1	ASTM-A216-WCB
02	End Cap	1	ASTM-A216-WCB
03	Ball	1	ASTM-CF8M-A351
04	Ball Seat	2	15% R-PTFE
05	Joint Gasket	1	PTFE
06	Stem	1	AISI 316
07	Thrust Washer	1	15% RTFE
08	Stem Packing	2	15% RTFE
09	Gland Nut	1	AISI 304
10	Handle	1	AISI 304
11	Spring Washer	1	AISI 304
12	Stem Nut	1	AISI 304
13	Handle Sleeve	1	Vinyl Grip
14	Lock Device	1	AISI 304