

GRAPHIC PROGRAM CONTROLLER (2CH)

DATA SHEET

PVH

This controller is a multi-function/high-performance program controller developed on the basis of many years of delivery records in the field of various industry machines used for temperature control. It assures program control with high accuracy, and is capable of using with many types of small production equipment. Also, it provides PLC (Programmable Logic Controller) link function for easy application to FA system, and is ideally used as a component of realizing CIM system.

FEATURES

1. **Complete monitoring operation with full-graphic display**
 - Two-channel operating condition can be monitored in real time. The pattern graph is blackened out with the lapse of time so the progress of operation can be checked at a glance.
 - The name of process being performed corresponding to time signal can be displayed (up to 100 names can be registered with 18 characters/process).
 - The horizontal scale (step/time) of temperature pattern display can be selected and displayed in actual pattern format.
2. **Program pattern (199 patterns (2700 steps, max) setting function**
This function is ideally suited for machines requiring a large number of patterns such as for small production systems.
3. **Adoption of memory card**
 - **Simple and positive program control**
Programs can be loaded by changing IC cards registered with programs of various items, allowing simple and positive control of program patterns of small production of many different articles.
 - **Compact data-base system**
Pattern data and PID parameters registered in formerly used PVH can be saved in IC cards for easy initial setting to newly purchased articles.
4. **Application to control of carbonization furnace and vacuum furnace**
Control of 2-process value, such as temperature/vacuum degree, temperature/pressure, temperature/humidity, etc., can be controlled with a single unit. The adoption of built-in CP (Carbon Potential) calculating function which is indispensable for control of carbonization furnace, contributes to cost down and space-saving.
5. **Application to FA system**
 - This controller can be used for FA system when used in combination with Fuji's FA components.
 - Lines between components are integrated by network (T-link communication), thereby providing system expansion which allows the user to set up FA system step by step, from PLC to group control of machines and to factory FA system.
 - RS422A/RS485 communication



SPECIFICATIONS

Size of front panel:

144 × 144 mm

Input:

Full multi-input (see section "Input")

Control action:

Auto-tuning PID operation (normal/reverse selection possible)
Manual operation function
Program/fix value control

Control output: (2 points)

• Relay contact output
• Voltage pulse output (for SSR drive)
• Current output

} (To be set according to code symbols)

IC card function (option):

Used to save program parameters in IC card

Display system:

LCD full-dot graphic display, 320 × 240 dots (with back light)

Program setting unit:

Program memory number:

199 patterns, max.

Max. step number:

2700 steps

Number of steps in 1 pattern:

99 steps, max.

Program setting range:

Time; 0.0 to 999.9 min/step, setting resolution 0.1 min

Setting range; 0 to 100% of input scale

Setting accuracy: Less than ±0.5 of full scale

Fast feed time function:

About 60 times the setting time
Time signal is OFF at fast feed with key operation.

Operation display:

The states of following operations are displayed on the front LCD panel.
Program run, program stop, program fast run, program reset, program end, selected program No., running step No., measured value (PV), set value (SV), operation output value (MV), operation output ON/OFF, program operation pattern, process name, time display

Input

(1) Analog input

Input signal, setting scale range:

Kind of input	Code	Temperature range [°C]	Temperature range [°F]
Resistance bulb IEC Pub 751-1983	Pt 100	0	0.0 to 150.0
	Pt 100	1	0.0 to 300.0
	Pt 100	2	0.0 to 500.0
	Pt 100	3	0.0 to 600.0
	Pt 100	4	-50.0 to 100.0
	Pt 100	5	-100.0 to 200.0
	Pt 100	6	-199.9 to 600.0
Resistance bulb JIS C 1604-1981	JPt 100	16	0.0 to 150.0
	JPt 100	17	0.0 to 300.0
	JPt 100	18	0.0 to 500.0
	JPt 100	19	0.0 to 600.0
	JPt 100	20	-50.0 to 100.0
	JPt 100	21	-100.0 to 200.0
	JPt 100	22	-199.9 to 600.0
Thermocouple	J	32	0.0 to 400.0
	J	33	0.0 to 800.0
	K	34	0.0 to 400.0
	K	35	0.0 to 800.0
	K	36	0.0 to 1200.0
	R	37	0.0 to 1600.0
	B	38	0.0 to 1800.0
	T	39	-199.9 to 200.0
	T	40	-150.0 to 400.0
	E	41	0.0 to 800.0
	E	42	-199.9 to 800.0
	S	43	0.0 to 1600.0
	N	44	0.0 to 1300.0
	U	45	-199.9 to 400.0
WRe5-26	46	0.0 to 2300.0	
PL-II	47	0.0 to 1300.0	
DC voltage	1 to 5V DC	64	Scale settable within -999 to +9999 (* To apply the current input, connect 250Ω (option) between terminal I1C and I1V to convert it into the voltage of 1 to 5V.
	0 to 5V DC	65	
	0 to 10V DC	66	
	0 to 1V DC	67	
	0 to 100mV DC	68	
	0 to 10mV DC	69	
DC current	4 to 20mA DC	64*	
CP input (CH2 only)		80	0.00 to 1.50 cp
		81	0.000 to 1.500 cp
		82	0.00 to 2.00 cp
		83	0.000 to 2.000 cp

Note: * Accuracy below -200°C is not guaranteed.
* In the range of R thermocouple 0 to 500°C, accuracy is ±1% FS.
* In the range of B thermocouple 0 to 400°C, accuracy is ±5% FS.
* In the range of resistance bulb input -199.9 to 850°C, UNDER is not displayed even at 0Ω input.
* When B wire is broken at resistance bulb input, UNDER or OVER is displayed.

Input resistance and allowable signal source resistance

Input signal	Input resistance	Allowable signal source resistance
Thermocouple	1MΩ or more	250Ω or less
Resistance bulb	—	Less than 10Ω per wire
Voltage input 4 to 20mA	External resistor 250Ω	—
Gerconia direct input	250MΩ or more	20kΩ or less

* Sampling cycle: 0.1sec

(2) Digital input signal

Signal: No-voltage contact (contact capacity; 12V DC, 2mA DC or more)

Input points: 16 points

- Start/stop command
 - Fast or step run command
 - Pattern transfer command
 - Monitor panel A/B select command
 - Program reset command
 - Gerconia sensor impedance check command
 - Pattern external select ENT
 - Pattern external select 10⁰ (4 points)
 - Pattern external select 10¹ (4 points)
 - Pattern external select 10² (4 points)
- } (as specified)

Output

(1) Control output

Control output:

- Normal/reverse PID action
- Proportional band(P); 0.0 to 999.9% (2-position action at P=0)
- Integral time(I); 0 to 3200 sec (integration cut at I=0)
- Derivative time(D); 0.0 to 900.0 sec (derivation cut at D=0)

(PID is stored in memory up to 9 kinds; 1 kind of PID can be set on each step of program pattern).

Time proportional cycle:

- 1 to 120 sec (setting resolution, 1sec)
- (setting is not required at current input)

Relay contact output:

- 220V AC/30V DC (resistive load)
- 1c contact
- Electric life, 100,000 operations or more
- Minimum ON/OFF current, 0.1A (24V DC)

Voltage pulse:

- ON; 10 to 18V DC
- OFF; 0.5V DC or less
- Max. current; about 20mA

Current output:

- 4 to 20mA DC (allowable load, 600Ω or less)
- Accuracy, ±1.0%FS

Output limiter:

High/low limiter
Setting range, -5 to 105%
Limiter high/low limit set value (pair) is stored in memory up to 9 kinds; 1 kind can be set at each step of program pattern.

Control cycle: 0.1sec

(2) Auxiliary analog output (option)

Output points:

2 points

Output data: Any of measured value/set value/operation value can be set on 2 points individually.

Output accuracy:

DC 1 to 5V }
DC 0 to 5V } Kinds of output: 1 to 5V DC, 0 to 5V DC, 0 to 10V DC
DC 0 to 10V } Any one can be set on 2 points individually by Dip SW (set to 1 to 5V prior to delivery from factory).

Scaling function:

Provided

(3) Digital output

Status signal (7 points)

- Open-collector output
- Output rating, 24V DC 10mA or less
- ELT ; CPU stop status
- IMP ; Impedance check error status
- RST ; Reset status
- RUN ; Program operation status
- HLD ; Program stop status
- WAIT ; Guarantee soak standby status
- END ; program end status

Time signal (10 points)

- Open-collector output
- Output rating, 24V DC 10mA or less
Setting is made at each step.

Alarm:

- 4 points
- High/low limit alarm, 2 points
 - High or low limit alarm, 2 points
- Setting range, 0 to 100FS
- High/low limit alarm setting can be made individually up to 9 groups; 1 group can be set at each step.
 - High or low limit alarm setting can be made only on 1 group in common with high/low limit.
 - Besides the above, setting of guarantee soak, maximum standby time alarm, and main body fault alarm are possible.

Indication function

(1) Set value (SV), measured value (PV) indication

Display system:

LCD display

Indication range:

0 to 100% FS (SV), -5 to 105% FS (PV)

Measured value indication accuracy:

±0.2% FS ± 1 digit (standard condition)
±1.0% FS ± 1 digit (CP value indication)
Cold junction temperature compensation error, ± 1°C
(thermocouple input)

(2) Program No. indication

Display system: LCD display (numeric value display)

Indication range: 1 to 199

(3) Program progress indication

Display system:

LCD graphic display (numeric display and graphic display)

Indication range:

Step No. 1 to 99, time remained or time lapse in step, or program progress total time

(4) Digital input/output and action display

Display system:

LCD display

Display item: Time signal (TS1 to TS10)

Operation status display (reset, start, stop, fast run, end, control output)
Alarm (1 to 4) output status
IC card battery life alarm display

Other functions:

Cycle operation:

Operation with repeated display of the same program pattern

Link operation:

Operation with linkage of program pattern

Optional functions:

Communication function:

T-link, RS422A, RS485

Auxiliary analog output:

Refer to "Output" section

General items:

RAS function: With watch-dog timer

Power failure protection:

Momentary power OFF of more than 20ms is regarded as power failure; automatic start after recovery of power.

Battery backup:

Lithium battery is used.
Battery life; more than 5 years at 0 to 40°C of ambient temperature at power OFF

Optional accessories

•**Comment loader**

Comment loader is a software used to register process names and comments (full size characters) in PVH IC card for displaying current process names, corresponding to time signal, on PVH.

Specifications: Japanese full size character; 18 characters/process

Required device (to be prepared by user)

Personal computer; Model FMR (Fujitsu) or PC9801 (NEC) and MS-DOS (Ver. 3.10 or above)

IC card reader/writer; Model MCRJ03 (Towa Electron Co.) Towa Electron: FAX 045-471-0071

TEL 045-471-0066

045+471-0061

Process name input method:

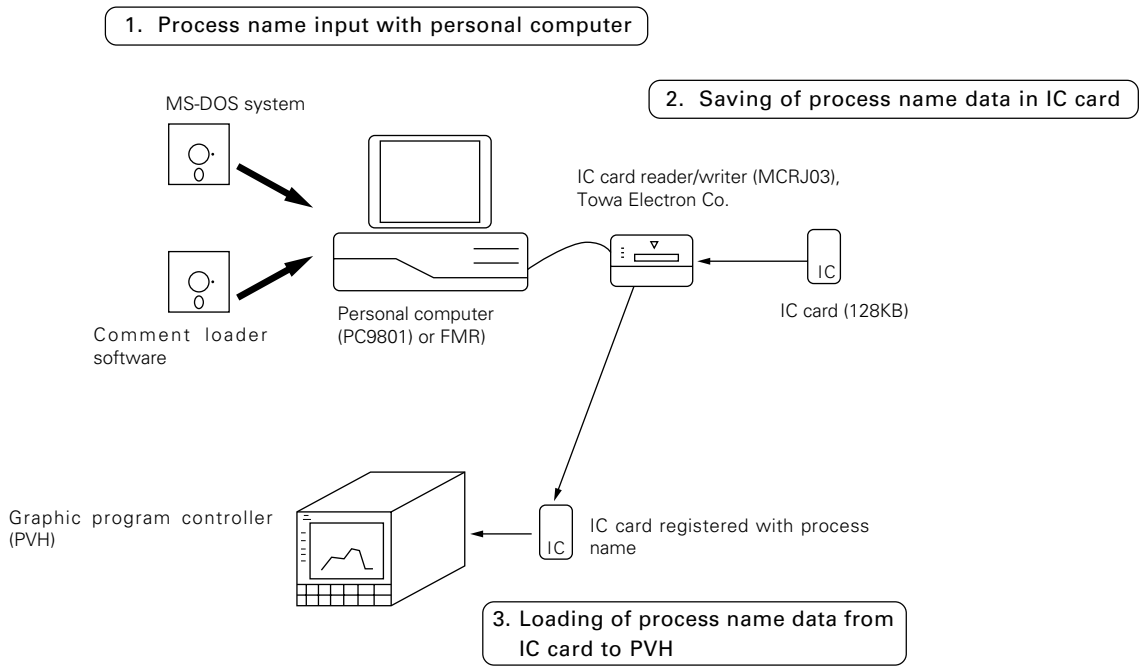

OUTLINE DIAGRAM (Unit:mm)

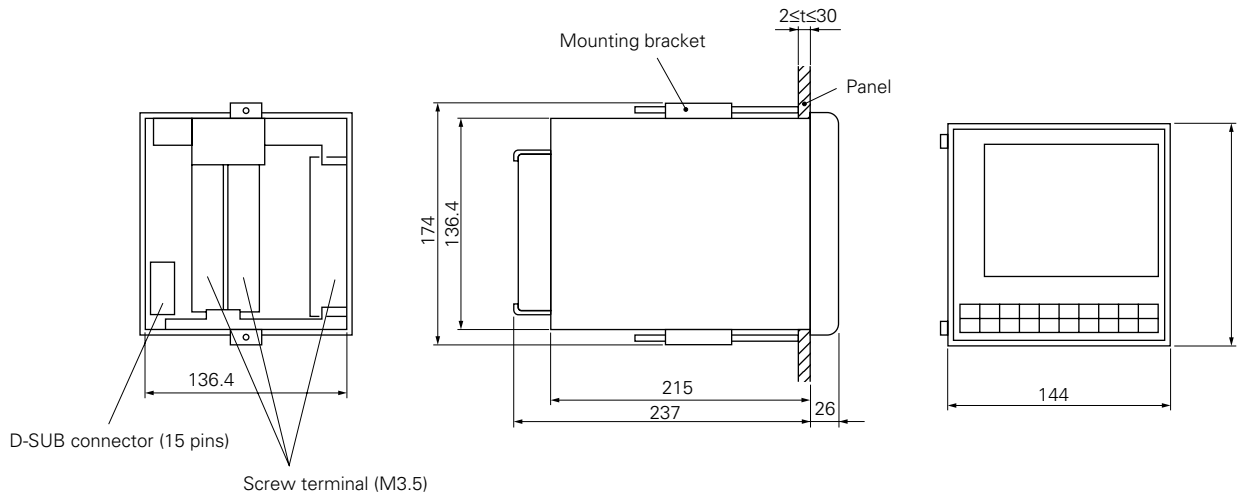

Panel cutout size

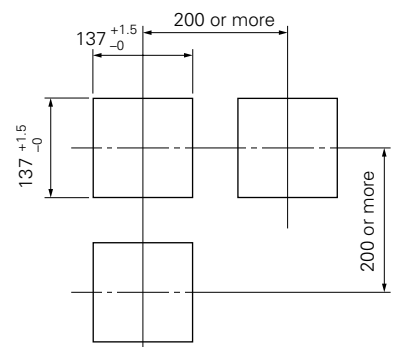

External connection diagram

External pattern select input (BCD code)

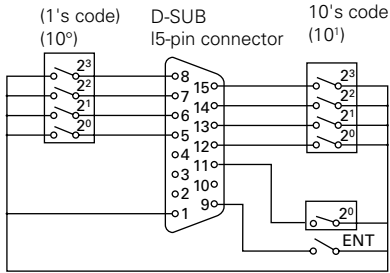

External pattern select input (pulse input)

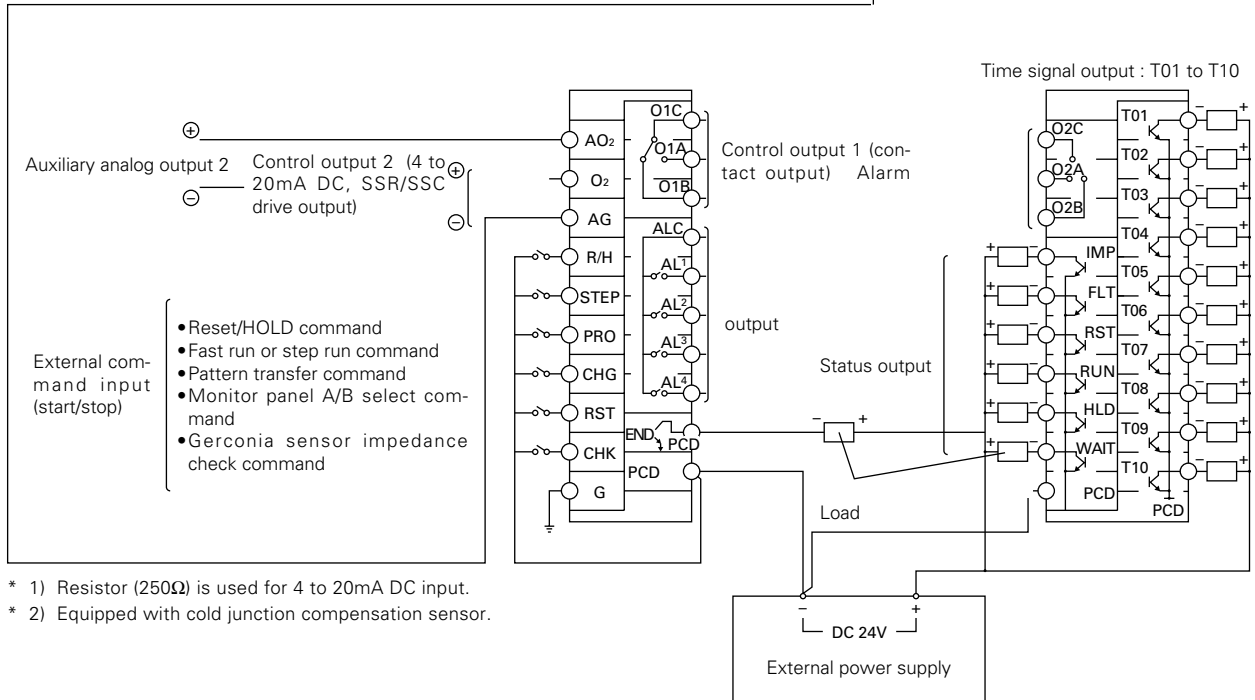
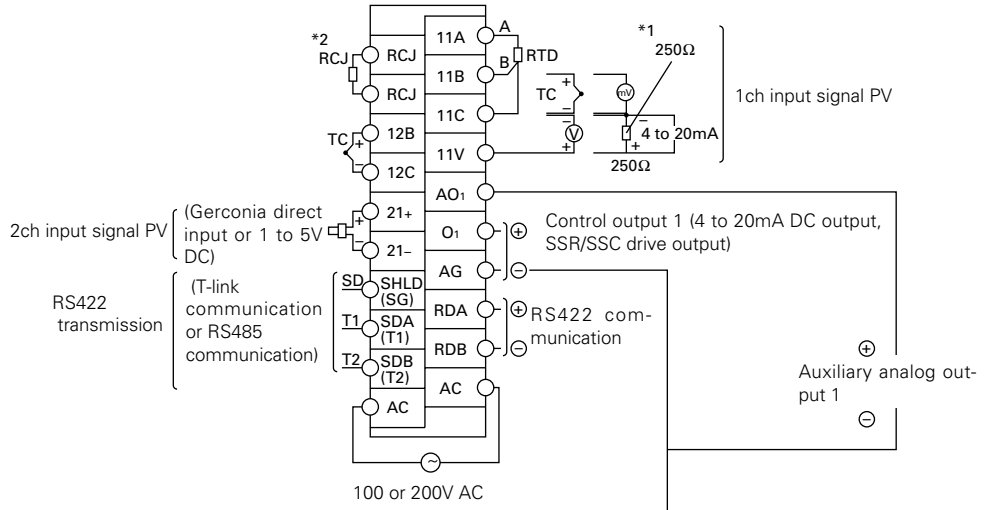
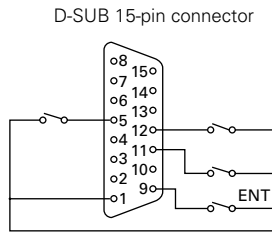

* 1) Resistor (250Ω) is used for 4 to 20mA DC input.
 * 2) Equipped with cold junction compensation sensor.

⚠ Caution on Safety

*Before using this product, be sure to read its instruction manual in advance.

Fuji Electric Systems Co.,Ltd.

Head office

6-17, Sanbancho, Chiyoda-ku, Tokyo 102-0075, Japan
<http://www.fesys.co.jp>

Fuji Electric Instruments Co.,Ltd.

Sales Div.

International Sales Dept.

No.1, Fuji-machi, Hino-city, Tokyo, 191-8502 Japan
 Phone: 81-42-585-6201, 6202
 Fax: 81-42-585-6187
<http://www.fic-net.co.jp>