

### Application

Commonly used in commercial, residential & general service applications. Ideal for general service on water, oil and compressed gas applications.

### Standard Features

#### Sizes

3/8" to 4" FNPT

#### Maximum Operating pressure

200 PSI/ 13.8 Bar

#### Body Material

Brass

#### Bonnet Material

Brass

#### Stem

Non-Rising Stem

#### Handle

Round hand wheel

#### Packing Material

PTFE

#### Temperature limits

-20° to 180°F (82°C)



## Dimensions

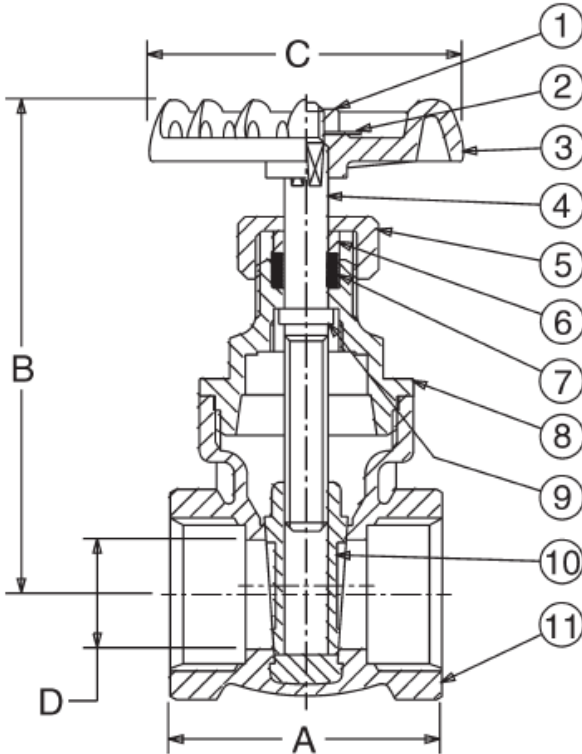

Size	"A"	"B"	"C"	"D"	Total Weight
1/2"	40.5	68.5	53	12	200g
3/4"	44	70	53	13	270g
1"	42	86	71	18	360g
1-1/4"	48	95	71	26	545g
1-1/2"	54	104	71	28	765g
2"	58	124	71	35	930g
2-1/2"	76	177	105.5	54	2270g
3"	94	193	126	65	4000g
4"	110	228	126	82	5800g

Dimensions in millimeters (mm)

PART	SPECIFICATION
1. Nut	Steel plated ASTM A 108 Alloy G10100
2. Name Plate	Aluminum ASTM B 209 Alloy 1100
3. Handwheel	Cast Iron ASTM A 48 Class No. 35
4. Stem	Brass ASTM B 16 Alloy C36000
5. Packing Nut	Brass ASTM B 16 Alloy C36000 or B 584 Alloy C85700
*6. Gland	Brass ASTM B 16 Alloy C36000
7. Packing	Graphite/Rubber Non-Asbestos
8. Bonnet	Brass ASTM B 584 Alloy C85700
9. Lock Nut	Brass ASTM B 16 Alloy C 36000
10. Wedge	Brass ASTM B 584 Alloy C85700
11. Body	Brass ASTM B 584 Alloy C85700

**Western Gauge & Instruments Ltd. – Head Office**  
 1,2 4045 – 74 Ave S.E.  
 Calgary, AB T2C 1H5  
 Ph: (403) 236-4888 Fax: (403) 236-7629  
 Email: sales@wgilt.com

**Western Gauge & Instruments Ltd. – Branch Office**  
 6624 – 50<sup>th</sup> Street  
 Edmonton, AB T6B 2N7  
 Ph: (780) 463-3800 Fax: (780) 463-3990  
 Email: edm@wgilt.com