

Application

WGI Elite 450 process gauge was engineered for the oil and gas and industrial process industries. The WGI elite 450 process gauge was also designed with the operator's safety in mind. In the event of over-pressuring resulting in a leak in the bourdon tube, a (blow-out back) solid wall separates internally from the ruptured bourdon tube forcing the process media through the back of the gauge.

Ranges (all ranges not stocked)

Vacuum / Compound to 30"Hg / 0 / 60 PSI

Pressure from 15 PSI to 15,000 PSI

Standard Features

Size

4½" Dial

Fill Fluid

Silicone

Lens (Window) Material

Acrylic

Dial

White aluminum with black and red lettering

Pointer

Black aluminum

Accuracy

± 0.5% ASME B40.1 Grade A

Tube & Socket

316 Stainless tube soldered to Stainless socket

Temperature Limits

-60°C (-4°F) to 70°C (158°F) ambient and medium

Pressure Ranges

-30" Hg. Vacuum to 15,000 psi/kpa

Case Material

Polypropylene



Optional Features (minimum order may apply)

Private label (your logo on dial)

Custom dial layout

Single scale, Bar, kPa, Kg/cm²

Rubber "gauge guard"

Cleaned for O2 Service

Nickel or Chrome plating

Plastic lens

Special connections limited to wrench flat area

Custom soldering connection for high temperatures

Stainless steel case

Brass case

Medical specification

Elite 450	
Connection	1/2" BTM
Pressure Range	4 1/2" Dial
30" Hg. Vac	WP5605P
30" Hg. x 30 psi	WP5612P
30" Hg. x 60 psi	WP5614P
0-15 psi / kpa	WP5640P
0-30 psi / kpa	WP5642P
0-60 psi / kpa	WP5646P
0-100 psi / kpa	WP5648P
0-160 psi / kpa	WP5652P
0-200 psi / kpa	WP5654P
0-300 psi / kpa	WP5658P
0-400 psi / kpa	WP5660P
0-600 psi / kpa	WP5664P
0-1000 psi / kpa	WP5668P
0-1500 psi / kpa	WP5674P
0-2000 psi / kpa	WP5676P
0-3000 psi / kpa	WP5678P
0-5000 psi / kpa	WP5682P
0-6000 psi / kpa	WP5684P
0-7500 psi / kpa	WP5686P
0-10000 psi / kpa	WP5690P
0-15000 psi / kpa	WP5692P
0-20000 psi / kpa	WP5694P

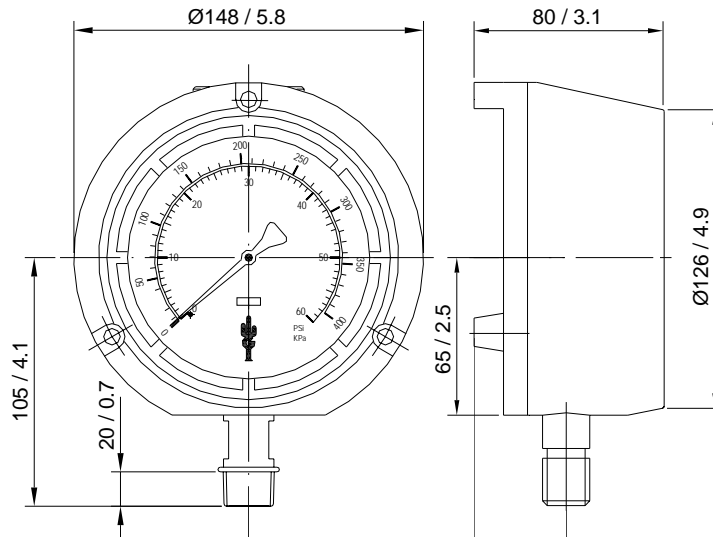

Western Gauge & Instruments Ltd. – Head Office
 1,2 4045 – 74 Ave S.E.
 Calgary, AB T2C 1H5
 Ph: (403) 236-4888 Fax: (403) 236-7629
 Email: sales@wgilt.com

Western Gauge & Instruments Ltd. – Branch Office
 6624 – 50th Street
 Edmonton, AB T6B 2N7
 Ph: (780) 463-3800 Fax: (780) 463-3990
 Email: edm@wgilt.com